

SeatTec

SEATS
THAT
KEEP
YOU
SAFE



SeatTec

SEATTEC IS
A PROFESSIONAL
AND INNOVATIVE
COMPANY WHICH
MADE A GOOD NAME
FOR ITSELF
**IN THE RANGE
OF SEATS.**

OUR VISION

As a manufacturer of seat systems for special vehicles, we would like to position ourselves in this niche market as a leading and significant partner for personal safety.

OUR MISSION

To offer the vehicle occupant best possible protection through innovative solutions and help him to accomplish his mission.

INNOVATION

Development of new products for personal protection based on the criteria of stability, weight, blasting safety, ergonomics and comfort.

With years of experience, the SeatTec team integrates the full process from design to manufacturing : development, prototype, construction, validation, homologation and serial delivery with the highest requirements. All safety metal parts are mainly produced by ourselves : forming, welding, milling and assembling.



VALIDATION, HOMOLOGATION

The seats are mainly in accordance with the standard regulation, validation and homologation. The customer specific requirement must be analysed and can be co-developed or co-tested with SeatTec.



P106
FAST BACK



FAST BACK SEAT OPEN



GENERAL COMPONENTS

FABRIC STANDARD COLOR: Cordura®



Natural beige

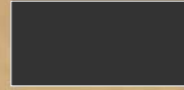

Black

ON DEMAND:



All defence and security patterns



Olive-green

FOAM HARDNESS:

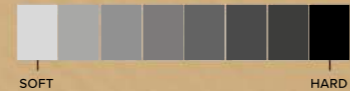

SOFT

HARD



REAR RACK FOR SETTING OF ADDITIONAL EQUIPMENT:



LONGITUDINAL ADJUSTMENT
Adjustment tracks +/- 100 mm



LATERAL HEADREST
can be set for all percentiles
Protects occupants from side collisions

SPECIAL COMPONENTS + SAFETY HARNESS > See pages 14/15

OPTIONS



PARAMETERS FAST BACK

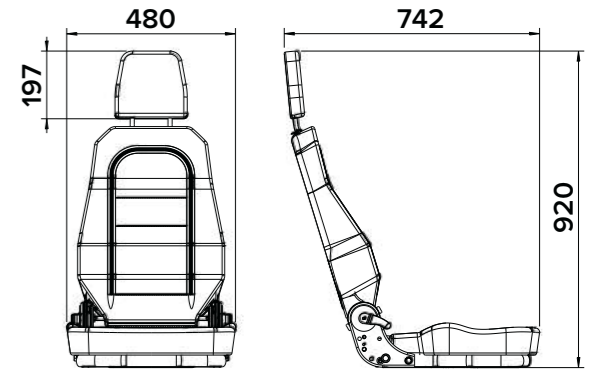

WEIGHT: 14,5 KG

PARAMETERS STANDARD

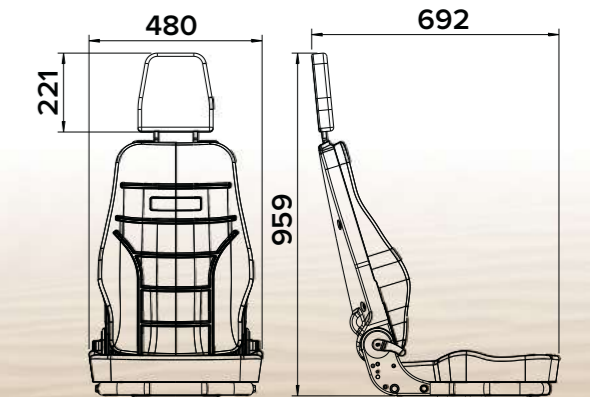

WEIGHT: 15,5 KG

PROTECTION

P106 BLAST DRIVER AND PASSENGER



PATENT N° 20 12689 irpi



FUNCTIONS

SAFETY

The Level 3b targets according to STANAG 4569 were successfully implemented.

PARAMETERS

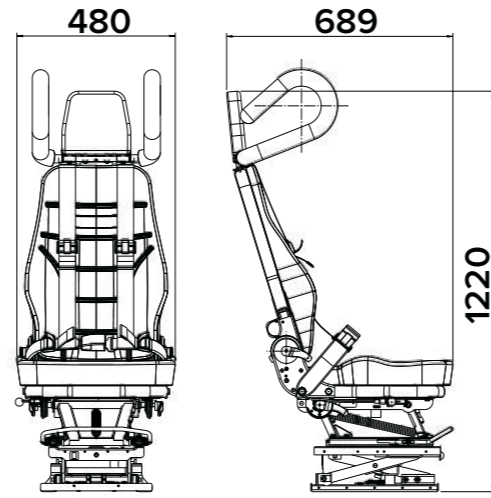

WEIGHT: 47,5 KG



PROTECTION

P106 BLAST FOLDING



FUNCTIONS

SAFETY

The Level 3b targets according to STANAG 4569 were successfully implemented.

PARAMETERS

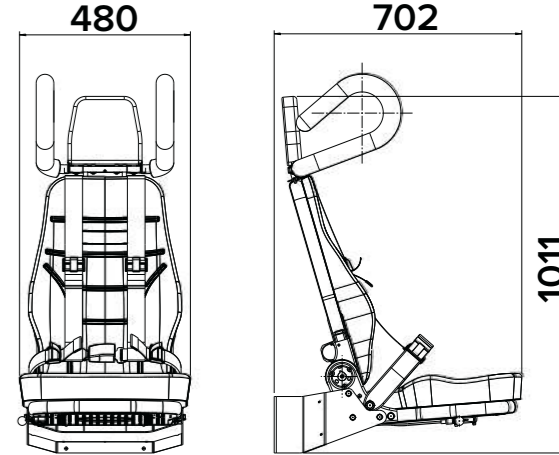

WEIGHT: 26 KG



SeatTec

P106
DRIVER AND
PASSENGER



FUNCTIONS



Floor fixation
in the vehicle



Foldable armrests



Backrest adjustment



4-point-harness
(optionally 3-/5- point/
automatic/static)



Longitudinal
adjustment
+/- 100 mm



Horizontally foldable
backrest can be used
as climbing assistance

Anti-slip coated
stepping area

GENERAL
COMPONENTS



LONGITUDINAL ADJUSTMENT
Adjustment tracks +/- 100 mm



LATERAL HEADREST
can be set for all percentiles
Protects occupants from side collisions



ARMREST FOR JOYSTICK
Adjustable



ARMREST
Foldable

SPECIAL COMPONENTS + SAFETY HARNESS > See pages 14/15



MULTIPOSITIONS
OPTIONS

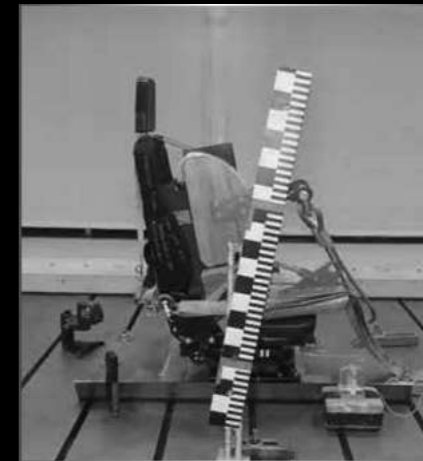

TEST ECE 14 +33% ✓



TEST ECE-R 17 ✓

PARAMETERS

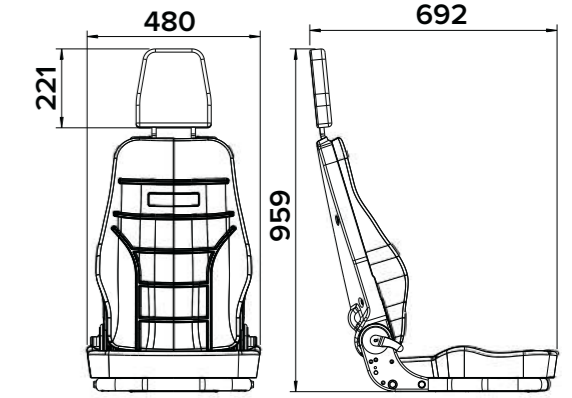

WEIGHT: 15,5 KG

P106
FOLDING



FUNCTIONS



Wall fixation
in the vehicle



4-point-harness
(optionally 3-/5- point/
automatic/static)



Backrest adjustment



Horizontally foldable
backrest can be used
as climbing assistance.



Foldable seat plate

Anti-slip coated
stepping area

GENERAL
COMPONENTS



LATERAL HEADREST
can be set for all percentiles
Protects occupants from side
collisions



FOOTREST
Can be stowed away
Height adjustable

SPECIAL COMPONENTS + SAFETY HARNESS > See pages 14/15



MULTIPOSITIONS
OPTIONS

PARAMETERS

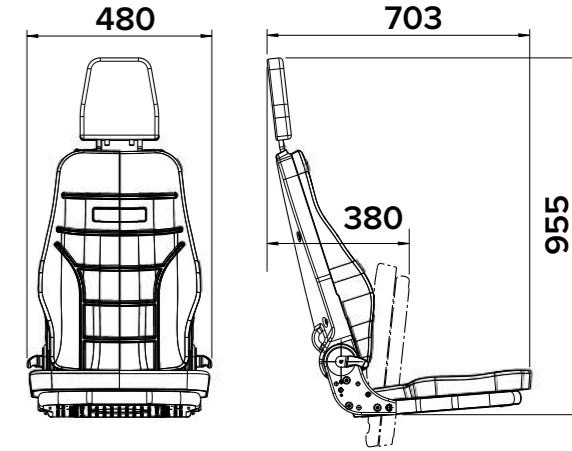

WEIGHT: 15,5 KG

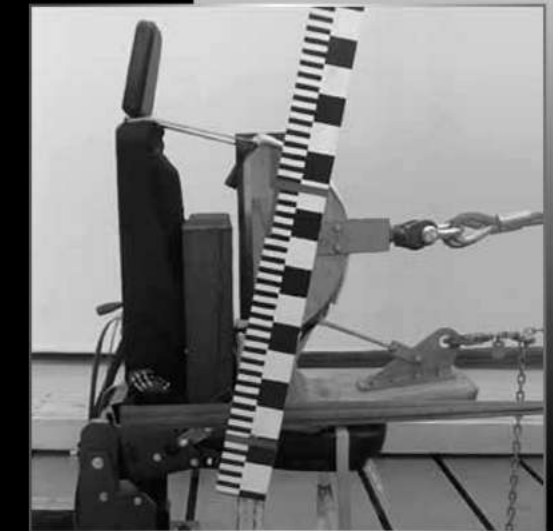

TEST ECE 14 +33% ✓



GENERAL COMPONENTS

FUNCTIONS



Individual fixing inside the vehicle, for example mounting on seat console



Backrest adjustment



Central safety belt



LONGITUDINAL ADJUSTMENT
Adjustment tracks +/- 100 mm

SPECIAL COMPONENTS + SAFETY HARNESS > See pages 14/15

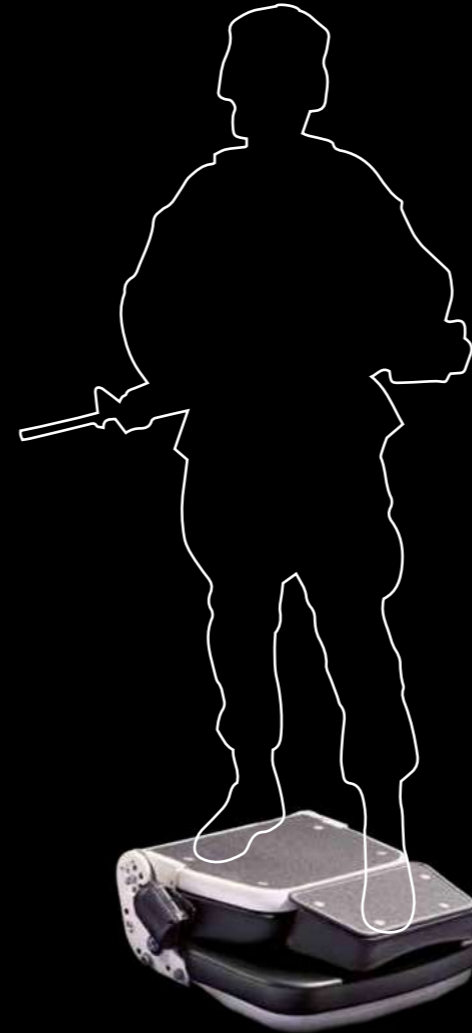

Horizontally foldable backrest can be used as climbing assistance

Anti-slip coated stepping area



PARAMETERS



480

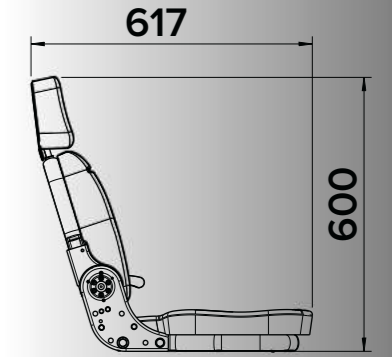

617

600

WEIGHT: 14 KG

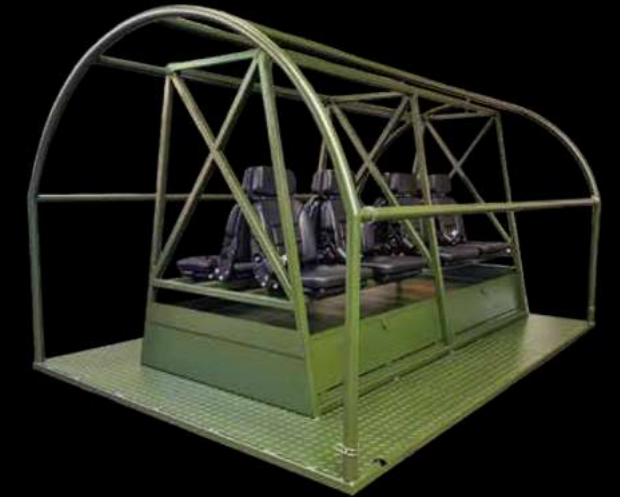

SPECIAL COMPONENTS HEIGHT ADJUSTMENT AND SUSPENSION



Mechanical height adjustment 60 mm



Gas spring height adjustment 60 or 80 or 100 mm



Air suspension



Rotation adapter

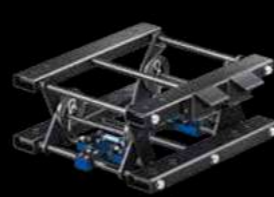

Height adjustment 80 mm with inclination front or rear from 12°



SAFETY HARNESS



5-point belt static with central buckle



4-point belt static with central buckle



3-point H belt automatic with static lock and central buckle



4-point H belt with central buckle



3-point H belt automatic with central buckle



4-point automatic belt with static lock and with central buckle



5-point belt automatic with central buckle



4-point belt automatic with central buckle

SPECIFIC APPLICATIONS



Special consol for customer request

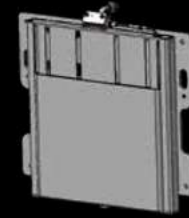

Height adjustment with gaz spring 100-250 mm very flat 40 mm



Special consol for customer request



Height adjustment mechanically hydraulic 300-600 mm more stroke on request

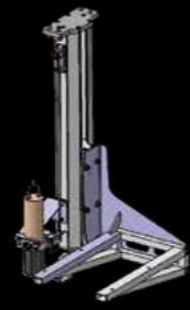

Height adjustment electro-hydraulic 300-600 mm more stroke on request



Height adjustment mechanically for folding seat 100 mm



Horizontally foldable backrest can be used as climbing assistance. Anti-slip coated stepping area with ladder to access



Height adjustment electro-hydraulic 300-600 mm more stroke on request



Height adjustment mechanically for folding seat 100 mm



Height adjustment with gaz spring 100-200 mm very flat 40 mm

MORE SAFETY BELTS POSSIBLE...

ROPS-4 ROLL OVER PROTECTION SYSTEM



TRUE TO ITS PROMISE "SEATS THAT KEEP YOU SAFE", SEATTEC PRESENTS ITS INNOVATION:

The ROPS pallet, the rollover protection system that offers safety and personal protection to troops on the move.

It has been extensively tested - under the mains regulations - and features a "twist locks" system for secure attachment to the vehicle platform.

According: ECE R66 Rev. 2
DIN 13500: 07/2018
Test N° 202458696



According: ECE R80
Test N° V240816001



According: ISO 3471: 2008
Test report N° 25/00869



Lateral load



Vertical load



Longitudinal load



Twist locks fixations

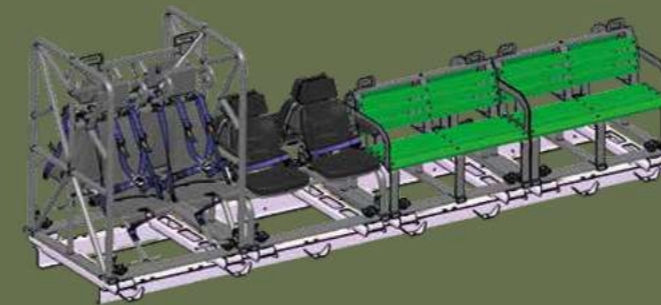

Various versions for transporting personnel **without specific approval, but which allow the use of the ROPS interface (dimension and Twist locks fixations).** Options available depending on customer requirements.



For the P110 version: with or without armrests and other features.



For the wooden version: with or without armrests and other features.

PARAMETERS

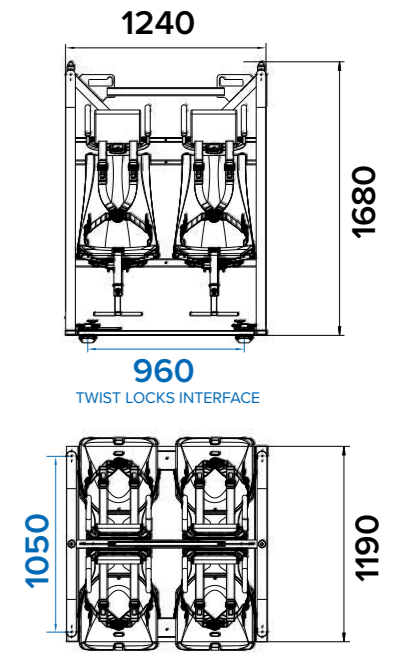

WEIGHT: 160 KG

CANVAS SEAT

The development of the ROPS system has also led to the development of a new lightweight seat, CANVAS Seat, which has been added to the range.

DELACOTEX
WORLD OF TECHNICAL TEXTILES
62256-0xx/407
Deliflame FR150

According: ECE 16
Approval N° E8*16R08/05*15846*00
TÜV SÜD Czech s.r.o.

According: ECE 14 + 33%
N° Z230906001
DEKRA

SeatTec

FUNCTIONS



Wall fixation in the vehicle



Foldable seat



4-point-harness statics
optional 5-point

GENERAL COMPONENTS



LATERAL HEADREST
can be set for all percentiles
Protects occupants from side collisions



FOOTREST
Can be stowed away
Height adjustable



POTENTIAL STORAGE VIA REMOVABLE BACKREST

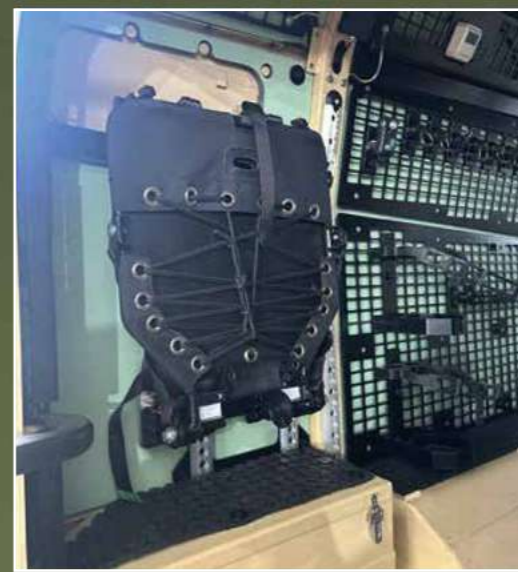

PARAMETERS

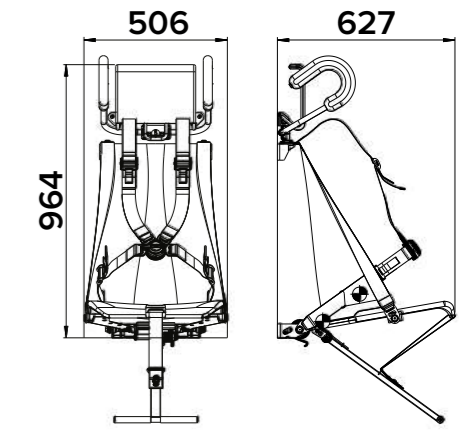

WEIGHT: 10,7 KG

TEST ECE 14 + 33% ✓

PROTECTION

EVO17
BLAST



PATENT N° 20 12689 inpi



SeatTec

COMFORT AND SAFETY

The new EVO 17 Protection combines successfully the two contradictions. With an ingenious technical solution, the advantages of a suspension seat can be combined with the high requirements of mine protection.

The Level 3b targets according to STANAG 4569 were successfully implemented.



BLAST TEST ✓

PARAMETERS

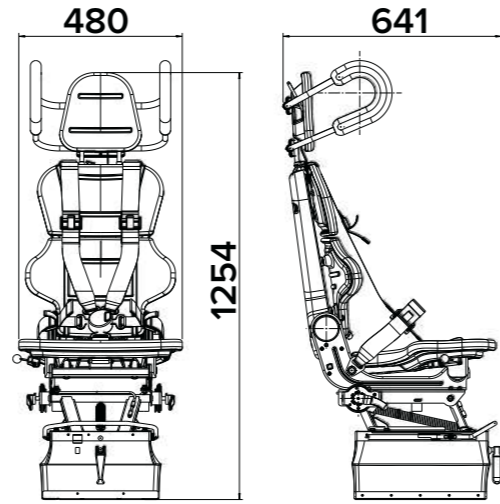

WEIGHT: 46,1 KG

PROTECTION

EVO18
BLAST



SAFETY

The Level 3b targets according to STANAG 4569 were successfully implemented.



BLAST TEST ✓

PARAMETERS

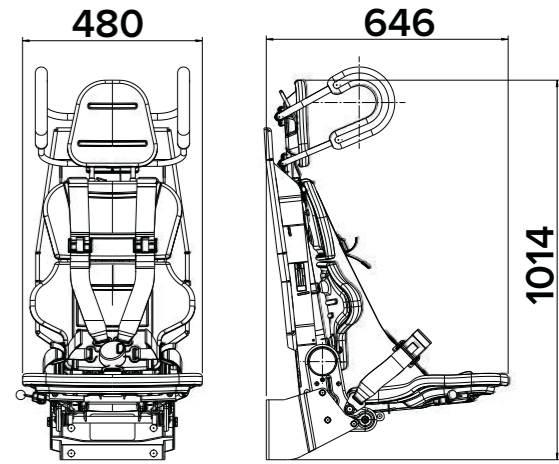

WEIGHT: 27 KG

EVO17
DRIVER AND
PASSENGER



FUNCTIONS



Floor fixation
in the vehicle



Foldable armrests



Backrest adjustment



4-point-harness
(optionally 3-/5- point/
automatic/static)



Longitudinal
adjustment
+/- 100 mm



Horizontally foldable
backrest can be used
as climbing assistance

Anti-slip coated
stepping area

GENERAL
COMPONENTS



LONGITUDINAL ADJUSTMENT
Adjustment tracks +/- 100 mm



LATERAL HEADREST
can be set for all percentiles
Protects occupants from side collisions



ARMREST FOR JOYSTICK
Adjustable



ARMREST
Foldable

SPECIAL COMPONENTS + SAFETY HARNESS > See pages 14/15

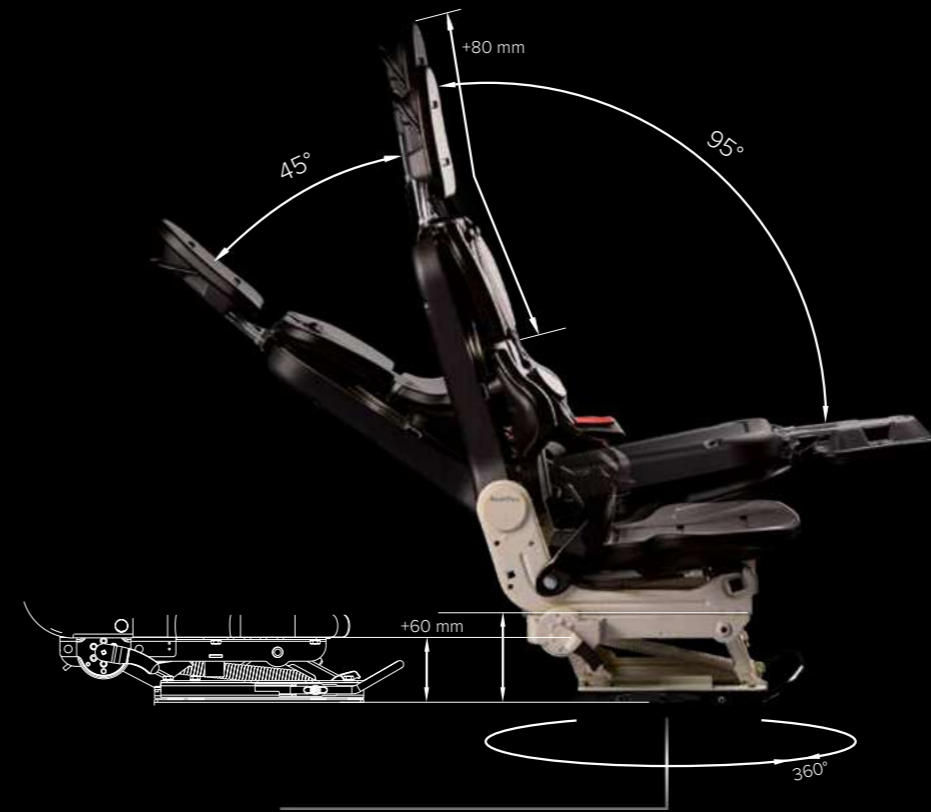

MULTIPOSITIONS
OPTIONS

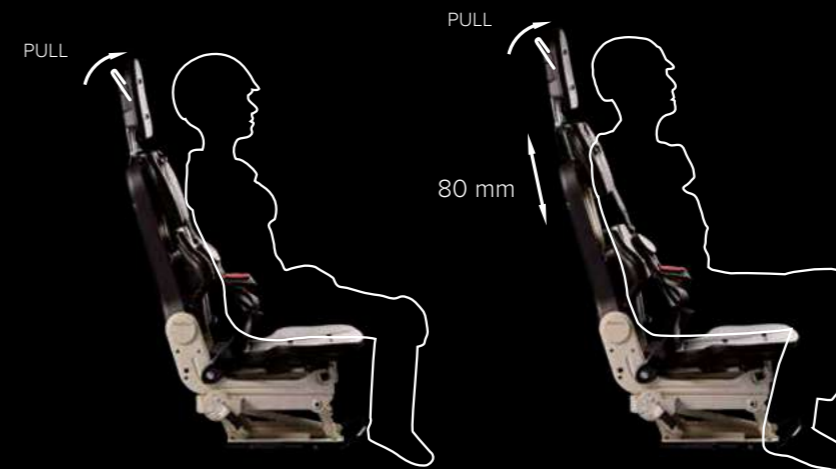

PARAMETERS

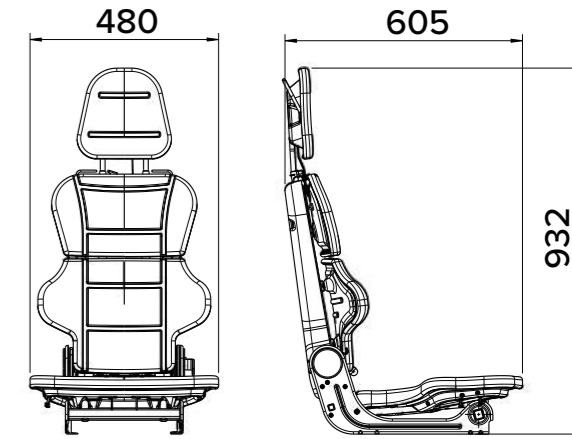

WEIGHT: 14,5 KG

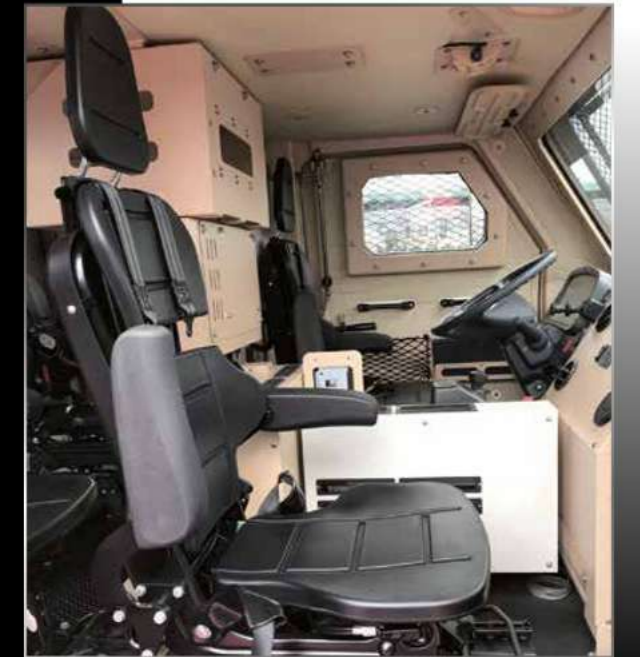

EVO18 FOLDING



FUNCTIONS



Wall fixation
in the vehicle



Backrest adjustment



Foldable seat plate



4-point-harness
(optionally 3-/5- point/
automatic/static)



Horizontally foldable
backrest can be used
as climbing assistance

Anti-slip coated
stepping area

GENERAL
COMPONENTS



LATERAL HEADREST
can be set for all percentiles
Protects occupants from
side collisions



FOOTREST
Can be stowed away
Height adjustable

SPECIAL COMPONENTS + SAFETY HARNESS > See pages 14/15



MULTIPOSITIONS
OPTIONS

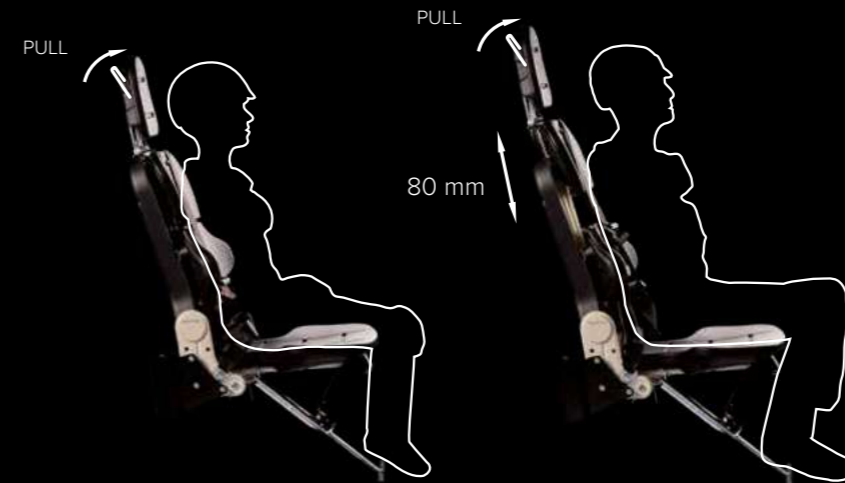

PARAMETERS

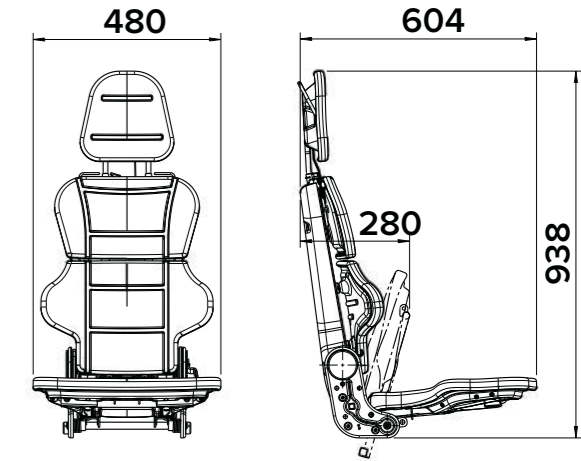

WEIGHT: 12,7 KG



**EVO19
RESCUE**



GENERAL COMPONENTS FUNCTIONS



Wall fixation in the vehicle



Floor fixation in the vehicle



Foldable seat plate



Backrest adjustment



4-point-harness static



LATERAL HEADREST
can be set for all percentiles
Protects occupants from side collisions



SPECIAL CONSOL
for customer request

SPECIAL COMPONENTS + SAFETY HARNESS > See pages 14/15

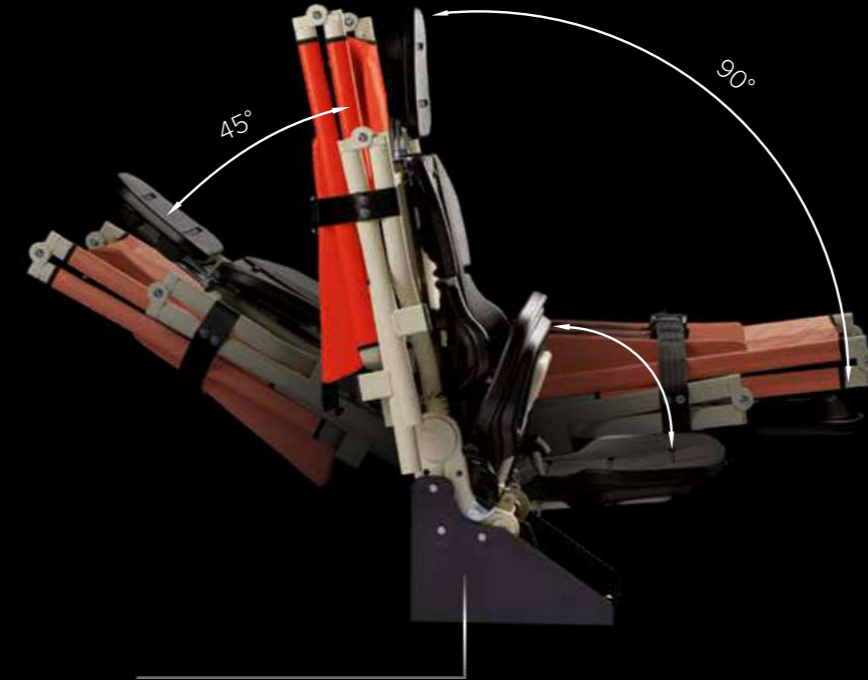

MULTIPOSITIONS
OPTIONS

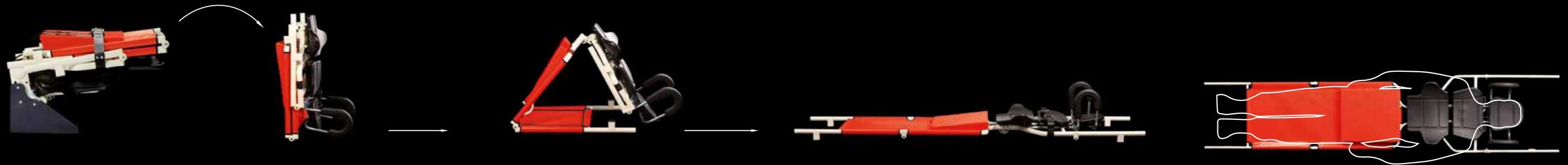

SEATS THAT KEEP YOU SAFE

SeatTec Group

SeatTec
Sitztechnik GmbH
D-92224 Amberg

info@seattec-group.de
seattecgrou.de 



CERTIFICAT
IS9001